

INVITATION TO BID (ITB)

FOR

KEYHOLE GARDEN CONSTRUCTIONS

THROUGH COMPETITIVE BIDDING

Issued by:

FH ASSOCIATION

House No # 121 (1st Floor), Road # 05, Mohakhali DOHS, Dhaka-1206, Bangladesh.

Phone: +8801700711617, 01755-532476

Web: www.fh.org/our-work/countries/bangladesh/

Tender Ref. No:
FH/Prolog/Tender/2026/04 Issued
on: 17.06.2026

Deadline for Submission: June 30, 2026.

Time: within 10.00 am Bangladesh Standard Time (BST)

This ITB document contains the

- Tender Invitation
- Section 2: Bid Data sheet
- Section 3: FH Invitation to bid general terms-conditions & policies**
- Section 4: Technical Description/ Specifications of the Bid/Goods
- Section 5: Bidding form**
- Section 6: Pricing Proposal
- Section 7: Suppliers Acknowledgement
Trade License, VAT and TIN Certificates, NIDs

Sections highlighted in green must be completed by the bidder

SECTION-2
BID DATA
SHEET
**1.BACKGROUND
DATA**

Tender Name: Keyhole Garden Constructions

This bid is issued by Food for the Hungry, FH Association, Bangladesh. Any correspondence can be addressed at the following address office.

FH Association (Food For The Hungry) Bangladesh
House No: 121 (1st Floor), Road No: 5, Mohakhali DOHS, Dhaka-1206.

Or Email: etender-fhb@fh.org

2. SCOPE OF SUPPLY:

The tender eligible for:

Description of the Supply Items:

SL#	Name of Item	Total Quantity
1	<i>Keyhole Garden Constructions for Chapai Nawabganj Area.</i>	<i>130 Units.</i>
2	<i>Keyhole Garden Constructions for Amtoli Area.</i>	<i>20 Units.</i>
<i>Total Keyhole Garden Constructions</i>		<i>150 Units.</i>

***FH Association has the right to add or deduct any quantity or items.**

3. SCHEDULE & DEADLINE FOR SUBMISSION:

Tender Publication Date	June 17, 2026
Start of Tender Submitting Date:	June 17, 2026
Pre-Bid Meeting Date and Time	June 22, 2026; 03:00 pm Microsoft Teams meeting Join: https://teams.microsoft.com/meet/279607380507160?p=DpVHkpctw4dmxdowjY Meeting ID: 279 607 380 507 160 Passcode: tj6YH7ZY
Tender Closing date and Time	June 30, 2026; 10:00 AM
Tender Opening Date and Time	June 30, 2026; 12:00 PM Microsoft Teams meeting Join: https://teams.microsoft.com/meet/279220476371339?p=6VucYsTnXKYacQKS44 Meeting ID: 279 220 476 371 339 Passcode: RE63t77E

* All times are in the local time of Bangladesh.

a. MANNER OF SUBMISSION:

Please submit your bids in accordance with the requirements detailed below:

Venue of Dropping for Tender Documents:	Food For the Hungry (FH Association) Bangladesh, Country Office, Department: Procurement & Logistics Address: House # 121 (1st floor), Road # 05, Mohakhali DOHS, Dhaka 1206. Or
Tender will also be accepted through the mentioned email address:	E-mail: etender-fhb@fh.org

4. LIST OF DELIVERY LOCATION:

Name of AP Office	Delivery Point			
Chapai AP Office	Jhilim CRC Jhilim Bazar, Amunura, Chapainawabganj Sadar	Atahar CRC Atahar, Nayagula, Chapainawabganj Sadar	Gobratola CRC Mohipur Bazar, Gobratola, Chapainawabganj Sadar	Shahjahanpur CRC Norendrapur Bazar, Shahjahanpur, Chapainawabganj Sadar
Amtoli AP Office	Chowra CRC, AK School Road, Amtali	Kukua CRC, Azimpur Bazar, Kukua, Amtali	Gulishakhli CRC, Gajkhali Bazar, Amtoli	Atharogasia CRC, Gazipur Bazar, Amtoli.

5. ASSESSMENT CRITERIA:

The reward of the contract(s) will be based on the following:

Step 1: Administrative compliance check

Bidders must provide evidence of the following for their bid to be considered compliant:

1. All sections completed, signed and stamped
2. A copy of their valid Update Trade License (Mandatory)
3. A copy of their VAT Certificate
4. A copy of their TIN Certificate business (Mandatory)
5. A Copy of BIN Certificate (Mandatory)
6. A copy of Tax Return Certificate
7. Bank Statement & Bank Details.

Step 2: Technical Evaluation

A Technical Evaluation of all bids received will be conducted to shortlisted bidders. Criteria that will be used to evaluate and score the bids are outlined in Section 3. FH may go for a sample test or factory visit if needed.

Step 3: Financial Evaluation

Price in comparison to FH established expectation and in comparison, to other bidders of comparable technical quality. FH Association reserves the right to award the tender or agreement in whole or in part or reject any bid and is not bound to accept the lowest offer.

SECTION-3

FH Invitation to Bid - General terms & conditions.

1. **SCOPE OF BID**

- 1.1. The tender/bid is based on the scope of the assignment as determined in the Bid Data Sheet (Section 2). The instructions to bidders should be read in conjunction with the Bid Data Sheet.
- 1.2. The successful Bidder / Tenderer will be required to complete the delivery of the goods and related services (when applicable) by the Intended Completion Date specified in the contract/PO to be signed.

2. **ELIGIBLE BIDDERS:**

- 2.1. A Bidder shall meet the following criteria to be eligible to participate in FH procurement:
 - the bidder, at the time of bid, is not:
 - i. insolvent.
 - ii. in receivership.
 - iii. bankrupt; or
 - iv. being wound up
 - All bidders should read, understand & acknowledge FH policies which attached to the annexures
 - The bidder has fulfilled his or her obligations to pay taxes and social security contributions. In a case where VAT is included in a bid, a copy of the VAT certificate must accompany the bid. A Bidder, and all parties constituting the Bidder including sub-contractors, shall not have a conflict of interest.
 - A Bidder whose circumstances in relation to eligibility change during a procurement process or during the execution of a contract shall immediately inform the FH Association.
 - FH reserves the right to refuse a bid at any time if the bidder or one of its sub -contractors provided material support or resources to any individual or entity that commits, attempts to commit, advocates, facilitates, or participates or is found guilty of fraud, active corruption, collusion, coercive practice, bribery, involvement in a criminal organization or illegal activity, or immoral human resources practices, including but not limited to: child labour, non-discrimination, freedom of association, payment of the legal national minimum wage, and forced labour.
 - Experience Criteria: At least 3 (three) years of overall experience in the supply of goods and related services.

3. **ONE BID PER BIDDER PER WORK**

- 3.1. Each Bidder shall submit only one Bid per contract. A Bidder who submits or participates in more than one bid per contract will cause all the bids with the Bidder's participation to be rejected. Also a bidder could participate for partial or product wise bid.

4. **COST OF BIDDING**

- 4.1. The Bidder shall bear all costs associated with the preparation and submission of his Bid, and the FH Association shall not be responsible or liable for those costs, regardless of the conduct or outcome of the bidding process.

5. **OBTAINING AND COMPLETING BIDDING DOCUMENTS**

- 5.1. The Bidder is expected to examine all instructions, forms, terms, and specifications in the Bidding Document. Failure to furnish all information or documentation required by the Bidding Document may result in the rejection of the bid.

6. **PRE-BID MEETING:**

6.1. A Pre-bid meeting will be held (as mentioned above) in the FH Country Office with the interested suppliers/ Vendors/ Providers for the clarification of the specifications of the Goods/ Products or others.

7. **CLARIFICATION OF BIDDING DOCUMENT**

7.1. A prospective Bidder requiring any clarification of the Bidding Documents shall contact the FH Association in writing. The FH Association will respond in writing to any request for Clarification before the deadline for clarification of bids. The FH Association shall forward copies of its response to all Bidders who have acquired the Bidding Documents, including a description of the inquiry but without identifying its source.

8. **AMENDMENT OF BIDDING DOCUMENT**

8.1. At any time, prior and until 48 hours prior to the deadline for submission of bids, the FH Association may amend or cancel the Bidding Document by informing the bidders in writing or in public notice.

8.2. To give prospective Bidders reasonable time in which to take an amendment or cancellation into account in preparing their bids, the FH Association can, at his discretion, extend the deadline for the submission of bids.

9. **LANGUAGE OF BID**

9.1. The bid, as well as all correspondence and documents relating to the bid shall be written in English.

9.2. Supporting documents and printed literature that are part of the bid may be in another language provided they are accompanied by an accurate translation of the relevant passages in English, in which case, for purposes of interpretation of the Bid, such translation shall govern.

10. **DOCUMENTS COMPRISING THE BID**

10.1. The bid submitted by the Bidder shall comprise the following:

- Signed and stamped Contractor's bid
- Any other information and documents requested.
- Pricing proposal
- Additional information on specification of Goods
- Signed and stamped Supplier Acknowledgement in **Section :7**

10.2. All forms must be completed without any alterations to the format, and no substitutes shall be accepted. All blank spaces shall be filled in with the information requested.

11. **BID PRICE FOR SUPPLY CONTRACT**

11.1. Bid prices are for the complete quantity of items required; the quantity in each category of items cannot be reduced.

11.2. Items for which no rate or price is entered by the Bidder will be as not quoted.

11.3. Unless otherwise specified in Section 2 - the Bid Data Sheet, all duties, taxes, and other levies payable by the contractor/supplier under the contract, shall be included in the total bid price submitted by the bidder. v

11.4. For bidder subject to VAT & Tax it should be mentioned in the offers

11.5. The Bidder is reminded that it is entirely his responsibility to ensure the accuracy of his bid. No alteration will be made to the bid after its submission on the grounds of any arithmetic errors subsequently discovered.

Note: All bidders must provide the price considering the Drawing, Design, BOQ and specification.

12. **CURRENCIES OF BID AND PAYMENT**

All prices shall be quoted by the Bidder in BDT, unless otherwise stated. Similarly, all payments will be made in BDT.

FH Association standard payment terms are within 30 days after the satisfactory implementation and receipt of products through account payee cheque.

13. **BID VALIDITY**

13.1. **Bids shall remain valid for a period of 90 days after the date of the bid submission deadline as prescribed by FH Association.**

13.2. **In exceptional circumstances, prior to the expiration of the bid validity period, the FH Association may request Bidders in writing to extend the period of validity of their bids. A Bidder must confirm in writing his acceptance of the extension. In case of extension, modification of the bid is not permitted.**

14. **ALTERNATIVE BIDS**

14.1. Bidders shall submit offers that comply with the requirements of the bidding documents, including the basic technical design as indicated in the drawings and specifications. Alternative bids shall not be considered unless otherwise indicated.

15. **FORMAT AND SIGNING OF BID**

15.1 The Bidder shall prepare one set of bid documents per tender that he wishes to bid for. The bidder should hold a copy of the documents with himself, for reference purposes.

16. **SEALING AND MARKING OF THE BID**

The Bidder shall enclose the bid for each tender in a plain envelope securely sealed or on etender-fhb@fh.org

16.1. The envelopes shall:

(a) be addressed to the Procurement & Logistics Department, Food for The Hungry, FH Association, in the location specified in

Section 2 – the Bid Data Sheet; for email, there must be a subject line.

(b) Bear the Contract number

(c) No other markings should be on the envelope

17. **DEADLINE FOR SUBMISSION OF BIDS**

17.1. Bids must be received by the FH Association at the address given and no later than the date and time indicated in Section 2 - the Bid Data Sheet.

18. **LATE BIDS**

18.1. FH Association shall not consider any bid that arrives after the deadline for submission as in Section 2 – the Bid Data Sheet. Any bid received by the FH Association after the deadline for submission of stipulated bids shall be declared late and rejected.

19. **DEADLINE FOR SUBMISSION OF BIDS**

19.1 Bids must be received by the FH Association at the address given and no later than the date and time indicated in Section 2 - the Bid Data Sheet.

20. **WITHDRAWAL AND REPLACEMENT OF BIDS**

- 20.1. A Bidder may withdraw or replace its bid after it has been submitted at any time before the deadline for submission of bids by sending a written notice, signed by an authorized representative. Any corresponding replacement of the bid must accompany the respective written notice.
- 20.2. After the opening of bids, modifications to bids must be documented and any discussions reported in writing. A bid may be withdrawn at any stage, with written notice.

21. **CONFIDENTIALITY**

- 21.1. Information relating to the examination, evaluation, comparison, and post-qualification of bids, and recommendation of contract award, shall not be disclosed to bidders or any other persons not officially concerned with such process until information detailing the best evaluated Bidder is communicated to all Bidders.
- 21.2. Any effort by a Bidder to influence the FH Association in the examination, evaluation, comparison, and post-qualification of the bids or contract award decisions may result in the rejection of its bid.
- 21.3. From the time of bid opening to the time of Contract award, if any Bidder wishes to contact with FH Association on any matter related to the bidding process, it should do so in writing.

22. **CLARIFICATION OF BIDS**

- 22.1. FH Association may, at its discretion, ask any Bidder for clarification of its Bid. The FH Association's request for clarification and the response shall be in writing. Any clarification submitted by a Bidder that is not in response to a request by the FH Association shall not be considered. All requests for clarifications shall be copied to all bidders for information purposes. No change in the price or substance of the bid shall be permitted, except to confirm the correction of errors.

23. **BIDS VALIDATION**

- 23.1. The FH Association's determination of a Bid's validity is to be based on the contents of the bid itself, which cannot be corrected if determined to be invalid.
- 23.2. A valid bid is one that complies with all the terms, conditions, and specifications of the Bidding Document, without deviation or omission.

24. **EVALUATION OF BID**

- 24.1. FH Association shall examine the legal documentation and other information (assessment criteria) submitted by Bidders to verify eligibility and then will review and score bids according to the following criteria.
- Competitive Price,
 - Overall timeframe for the delivery of the requested goods,
 - Ensure products quality,
 - Accurate calculations,
 - Previous reputation, and performance of supplier,
 - Adherence to FH Association's policies.
- 24.2. FH Association reserves the right to make an award based solely on the quotations received, to modify the requirements prior to awarding, or to negotiate further with one or more suppliers. FH Association reserves the right to award a contract to the supplier who, in their sole opinion, provides the best combination of cost and quality benefits.
- 24.3. Anti-money laundering, anti-bribery, anti-corruption, and anti-terrorism legislation applicable in some jurisdictions may require FH Association to verify the identity of the bidder prior to financial transactions. FH Association reserves the right to use online screening tools to check the bidder's record with regard to their possible involvement in illegal or unethical practices.

24.4. The FH Association reserves the right to reject all bids, and re-tender if no satisfactory bids are submitted.

25. **AWARD PROCEDURE**

25.1. The FH Association shall award the bid in writing, with an award letter, to the Bidder whose offer has been determined to be the best, before the end of the bid validity period

25.2. Any bidder who has not been awarded a contract will be notified in writing.

25.3. Until a formal PO is prepared and executed, the Award Letter shall constitute a binding agreement between the bidder and FH Association.

The Bidder is thereafter required to submit a Letter of Acceptance, confirming their wish to proceed with for PO.

26. **SIGNING OF CONTRACT**

26.1. Upon receipt of the Letter of Acceptance, the FH Association shall call the successful Bidder to sign the PO.

26.2. Within an agreed timeframe, the successful Bidder shall sign, date, and return the PO to the FH Association

SECTION-4
**TECHNICAL DESCRIPTION OF THE
GOODS**

Food for the Hungry (FH Association) Bangladesh is undertaking this Bid Process to have supply of these materials through the PO and subject to extension of both parties agreed:

Categories of Items	Quantity	Specifications
Keyhole Garden	150 Units.	As per attached Drawing, Design, BOQ & Specification

- **Items should be delivered in different areas as mentioned (in Article 4).**
- **The packaging is subject to the requirement and quantity of items.**

FH Association will place Purchase Orders (POs) as and when we require one or multiple items in the agreed list of items.

Please submit the following Documents along with the bids (these are mandatory submissions – if the following mentioned documents are not submitted then the bid might be disqualified)

- **Sections 5-7 completed, signed and stamped.**
- **A copy of Trade License (Mandatory)**
- **A copy of their valid BIN (Mandatory)**
- **A copy of their VAT Certificate license**
- **A copy of their TIN business license (Mandatory)**
- **Tax Return Certificate (Mandatory)**
- **Bank Statement & Bank Details (Mandatory)**

FH Association will pay through A/C Payee Cheque after the Items mentioned in the POs are delivered and correct invoices are submitted to FH Association, Country Office.

FH Association shall deduct VAT & TAX as per govt. policy if applicable and will deposit the deducted tax to the designated Government Bank & will provide the challan (receipt) to the service provider within 30 Days.

**SECTION 5:
BIDDING
FORM**

Please provide information against each requirement.

Additional rows can be inserted for all questions as necessary. If there is insufficient space to complete your answer in the space provided, please include on a separate attachment with a reference to the question.

1. Bidder's General Business Details

a) General information

Company name:	
Any other trading names of company:	
Registered name of company (if different):	
Nature of primary business/trade:	
Primary contact name:	
Job title:	
Phone:	
Email:	
Registered Address:	
Business license number:	
Country of registration	
Registration date:	
Expiry date:	
Legal status of company (e.g. partnership, private limited company, etc.)	

b) Owners/Managers

Please fill in the table below with the full names and the year of birth of the company's owner(s) and manager(s)*:

Full name	Residential Address	Year of birth

** Please note this information is necessary in order to conduct the vetting procedure referred to in clause 25 of the Invitation to Bid-General Terms and Conditions.*

c) Employees

Please list the employees who would be involved with FH Association in the event of contract award:

Employee name	Job title	Role on FH	Phone	Email
1.				
2.				
3.				

d) Company bank account details:

Beneficiary name:

Beneficiary account no
 Beneficiary Bank:

Bank branch:

Bank address:

2. References

Please provide details of at least 3 client references whom FH may contract, agencies, for similar related works:

Client/company name	Contact person	Phone	Email	Contract details (works, location, size, value, etc)
1.				
2.				
3.				

3. Bid Validity

Please confirm the validity of your bid below (in calendar days): (FH expects the bid to be valid for a period of 90 days), If any option arises to make a framework agreement choose the option below:

- a) In the event of a contract award, please confirm you are willing to enter into a fixed price agreement with FH Association.
- Yes
 No

4. Confirmation of Bidder's compliance

We, the Bidder, hereby certify that our Bid is a genuine offer and intended to be competitive and we confirm we are eligible to participate in public procurement and meet the eligibility criteria specified in the Invitation to Bid. We confirm that the prices quoted are fixed and firm for the duration of the validity period and will not be subject to revision or variation.

The following documents are included in our **Bid**: (please indicate which documents are included by **ticking the boxes below**).

Documents	Included
Section 5: Bidding form; completed, signed and stamped	<input type="checkbox"/>
Section 6: Pricing Proposal; completed, signed and stamped	<input type="checkbox"/>
Section 7: Additional Information on Specifications of Goods; completed, signed and stamped	<input type="checkbox"/>
Section 8: Supplier's Acknowledgement	<input type="checkbox"/>
Copy of valid business license, VAT Certificate, TIN Certificate and NIDs of the Proprietor/Partners	<input type="checkbox"/>

We understand that FH Association is not bound to accept the lowest, or indeed any bid, received. We agree that FH Association may verify the information provided in this form itself or through a third party as it may deem necessary.

We confirm that FH may in its consideration of our offer, and subsequently, rely on the statements made herein.

Name of Signatory:	Mobile No:
Title of Signatory:	Name of Company:
Signature & stamp:	Date of Signing:
	Address:

**SECTION 6:
BIDDING
FORM**

FH Note:

1. Please mention all the items that you can provide they should be packaged in your stock of All the available different brands, weight, sizes and rates; FH Association is looking for Items that has govt. approval.
2. Please fill in all the sections:
 - 2.1. Item Description Means the Common name the item is known as or what is written on the Packet
 - 2.2. Brand/Company – Name of the Company/Brand the item.
 - 2.3 Weight/Size of the items must be mentioned
 - 2.4 Must be mentioned if any other specification contains for items to identify the items
3. Delivery in FH Area Program Offices.
4. Vat & Tax (as per Govt. Rules) & Transportation and other relevant costs should be mentioned in the final price

S/N	Items Description	Brand/ Company Name	UoM	Qty	Unit Cost	Total Cost	Remarks
1			Units				
2							

Mention Delivery Time (in calendar days): The order quantity would single or multiple as per requirement of FH through the PO with you.	Days:
--	-------

Note: Sample will have to be delivered free at FH's Mentioned Locations.

We understand that you are not bound to accept the lowest or any bid received.

Name of Signatory:	Mobile No:
Title of Signatory:	Name of Company:
Signature:	Date of Signing:

SECTION: 7

Supplier's Acknowledgement

- *Code of Conduct*
- *Anti-Harassment*
- *Safeguarding*
- *Whistleblower Policy*

I, _____ agree to follow the spirit and intent of Food for the Hungry's Global Code of Conduct, Safeguarding Policy, Anti-Harassment Policy. Also agreed to work with them by following the policy procedures. Even compliance with all applicable laws and regulations and meet the ethical standards as listed above, or positively agree to these ethical standards and are willing to go forward with this organization.

Misrepresentation above may result in cancellation and severing all ties with the agency/person and will be delisted from FH's database of suppliers. I have understood all the policy statement and certify under oath that the information contained herein is true and accurate to the best of my knowledge and belief.

- ***CERTIFICATION REGARDING TERRORISM: Seller hereby certifies that it has not provided and will not provide material support or resources to any individual or organization that it knows, or has reason to know, is an individual or organization that advocates, plans, sponsors, engages in, or has engaged in an act of terrorism.***

We, the undersigned, verify that,

DATE:

NAME OF SUPPLIER/COMPANY: _____

NAME OF REPRESENTATIVE: _____

SIGNATURE: _____

COMPANY STAMP: _____

FH Association Bangladesh
Amtali & Chapainawabganj Area Program
Drawing Title: Construction of Keyhole Garden

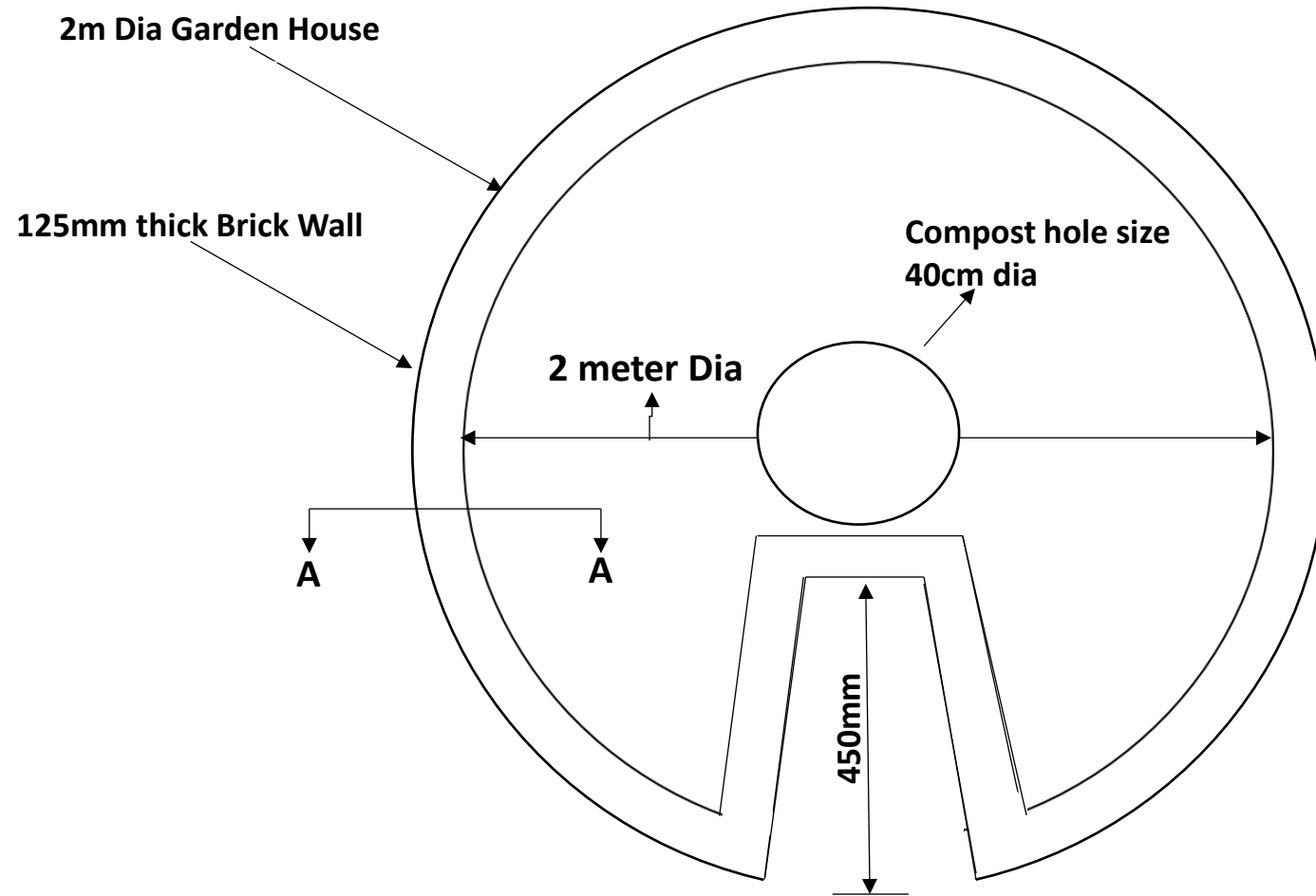

FH Association Bangladesh
Amtali & Chapainawbganj Area Program
Drawing Title: Construction of Key Hole Garden

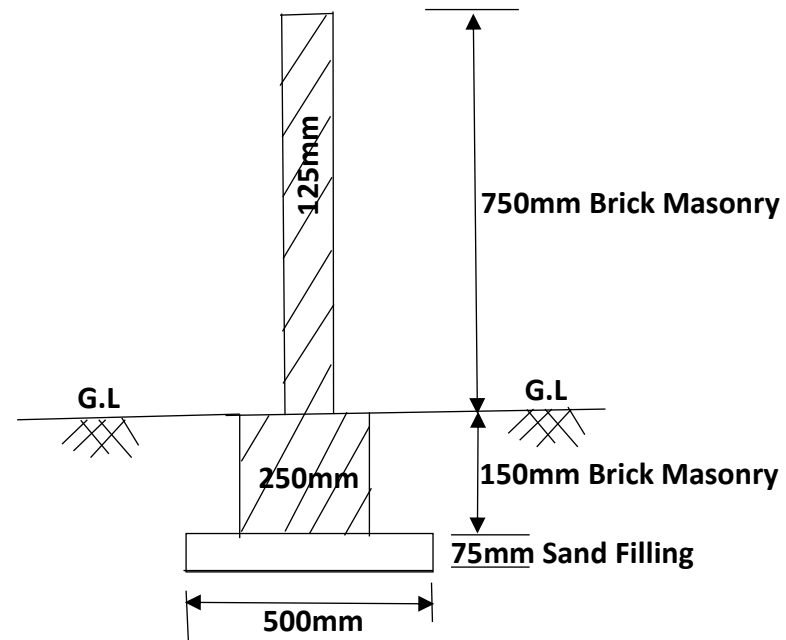

Drawing "Section A-A"



View of Keyhole Garden

FH Bangladesh
Amtali & Chapainawabganj Area Program
Bill of Quantities
BoQ of a Keyhole Garden



SL. No.	Description	Unit	Quantity	Rate (BDT)	Amount (BDT)
1	Earth excavation work in all kinds of soil for foundation trenches including layout, providing center lines, levelling, ramming and preparing the base. all complete and accepted by the Engineer-in-charge, subject to submit method statement of carrying out excavation work to the Engineer-in-charge for approval.	cum	0.85		
2	Sand filling in foundation trenches having F.M. 0.5 to 0.8 in 75 mm layers including leveling, watering and compaction to achieve minimum dry density of 95% with optimum moisture content (Modified proctor test) by ramming each layer up to finished level as per design supplied by the design office only, all complete and accepted by the Engineer-in-charge.	cum	0.28		
3	Providing and constructing 250 mm thick brick masonry (Below GL=6", Above GL=3") wall using 1st class bricks in cement sand mortar (1:5), laid in proper line, level, and stretcher/header bond as required. The work includes mixing mortar, laying bricks, joint finishing, curing, scaffolding, labour, tools and all necessary materials to complete the work as per approved design and direction of the engineer.	Cum	0.285		
4	Providing and constructing 125 mm thick brick masonry wall using first-class bricks in cement mortar 1:4 (1 part cement : 4 parts sand), laid in stretcher bond, including proper curing, scaffolding, finishing and cleaning of the surface. The wall is to be built up to 750 mm height from GL as per approved design for the Keyhole Garden, including openings for keyhole access. The work includes supply of bricks, mortar, scaffolding, labour and tools, all work shall conform to the specifications and directions of the Engineer.	sqm	5.69		
5	Supply, fabrication and vertical installation of a 40 cm diameter and 750 cm (30 inches) deep central compost hole/basket using two-layer Net / Galvanized Iron (GI) wire mesh at the center of the keyhole garden. The basket shall be lined with thatching grass or straw to allow water and nutrients to flow into the surrounding soil. The hole is used to deposit organic waste such as vegetable scraps, eggshells, dry manure and compost, which decompose and continuously supply nutrients to the garden soil. The basket shall be firmly fixed vertically within the garden layers to facilitate easy addition of compost materials and greywater, including the cost of all necessary materials and tools as per technical specifications.	Nos	1.00		
6	Supply of skilled mason and helper for complete construction of keyhole garden including all related works	Nos	2		
Sub Total /=-					-

FH Bangladesh

Keyhole Garden

**FOOD FOR
THE HUNGRY**
Component of Inner Layer for Keyhole Garden

Sl	Layer / Item	Description	Unit	Qty (Approx.)	Unit Cost	Total	Remarks	Comments
1	Layer 1	Brick bats / stones (drainage layer)	m3	0.3			ভাঙা টিন / ক্যান, পশুর শুকনো হাড়, ভাঙা মাটির পাত্র বা পাথর	মাঝখানের কম্পোস্ট বিনে থাকবে: সবজির খোসা, ডিমের খোসা, শুকনো গোবর, কম্পোস্ট যা হাউজহোল্ডার ব্যবস্থা করবে।
2		Broken cans / metal scraps (optional mineral source)	Kg	5				
3	Layer 2	Top soil	m3	0.6			পুষ্টিকর মাটি, খড় বা শুকনো ঘাস, কাঠের ছাই (পটাশিয়াম দেয়)	
4		Dry grass / thatching grass	Bundle	2				
5		Wood ash	Kg	5				
6	Layer 3	Mixed soil + dry manure	m3	0.6			মাটি + শুকনো গোবর	
7		Signboard(18"X12") with metal post	Nos	1				
Total in BDT=								

FH Bangladesh
Amtali & Chapainawabganj Area Program
Materials List
Keyhole Garden



SL. No.	Description	Unit	Quantity	Rate (BDT)
1	Earth excavation work	cum	0.85	
2	Filling Sand (FM: 0.8-1.2)	cum	0.28	
3	1st class Bricks	Nos	425	
4	Sand (Working Sand, FM: 1.2-1.8)	cum	0.3	
5	Cement (Clinker: 65-93%)	Bags	2.5	
6	Polythene Laying	sqm	2.28	
7	40 cm diameter and 750 cm (30 inches) Height two-layer Net / Galvanized Iron (GI) wire mesh	Nos	1.00	
8	Skilled & Semi-Skilled Worker (Mason)	Nos	2	
Sub Total /=				

**D FOR
HUNGRY**

Amount (BDT)
-
